

TOP VIEW

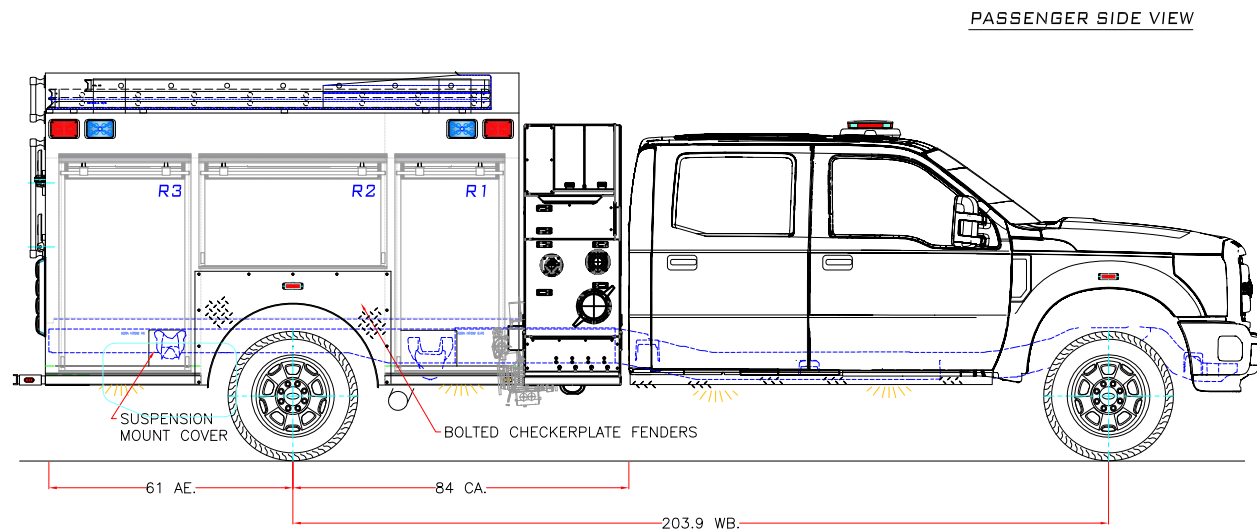

PASSENGER SIDE VIEW

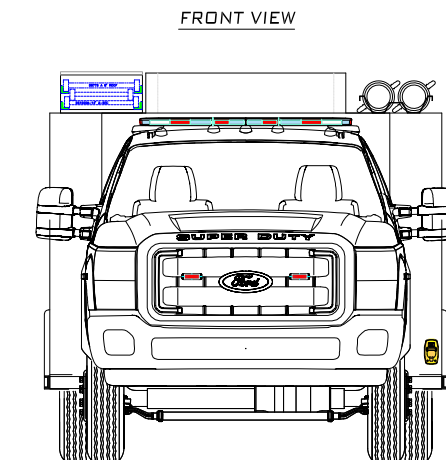

FRONT VIEW

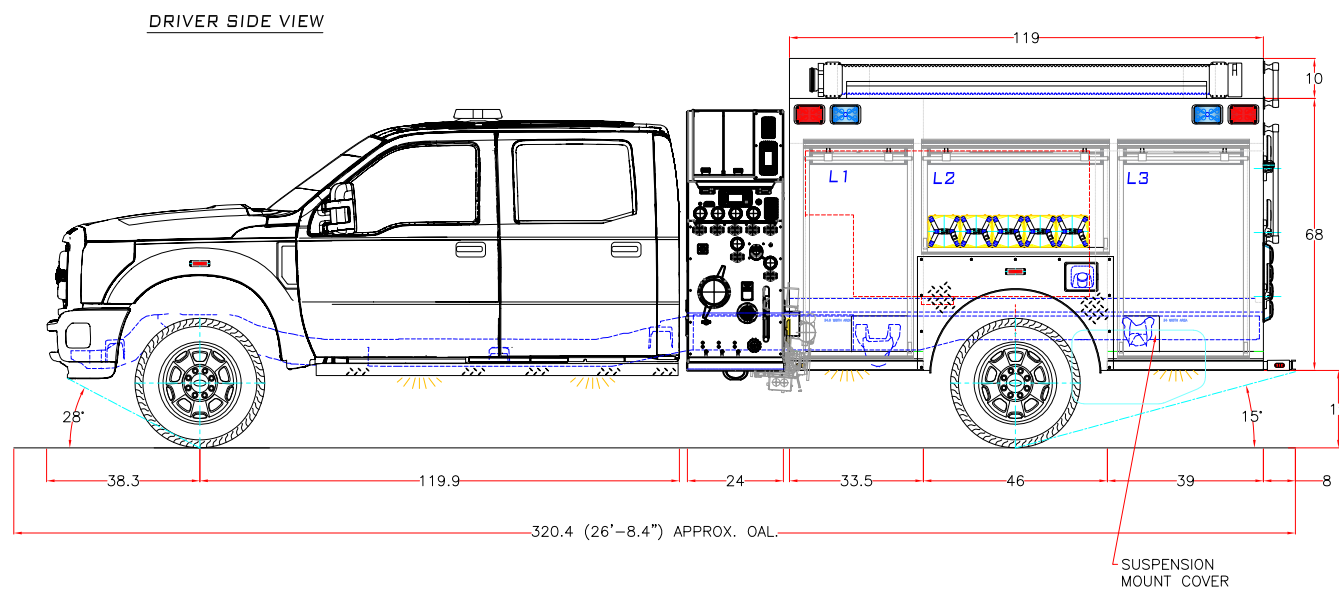

DRIVER SIDE VIEW

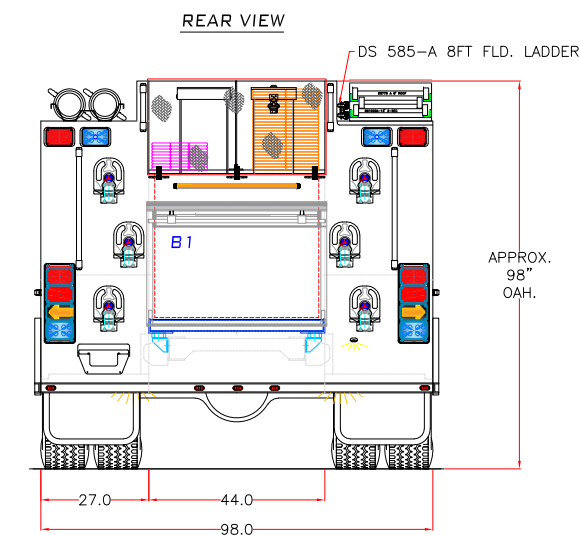

REAR VIEW

CAB

CAB & CHASSIS MODEL:	2023 F550 4X4 SD CREW CAB
ENGINE:	6.7 4V POWER STROKE DIESEL V8
HORSEPOWER:	350HP @ 3900 RPM
ENGINE TORQUE:	468 LB/FT. @ 3900 RPM
TRANSMISSION:	TORQSHIFT 10 SPEED AUTO
GVWR:	20,706 LBS.
FRONT AXLE RATING:	6,000 LBS.
REAR AXLE RATING:	14,706 LBS.

BODY MATERIAL

.188 5052 H32 MARINE GRADE ALUM.
.188 & .125 3003 H22 ALUM. CHECKER PLATE ALUMINUM EXTRUSION

PUMP

HALE DSD 1500GPM

FOAM SYSTEM

WATER TANK

300 USG POLYTANK
(OPTIONAL 20 USG FOAM)

COMPARTMENT DIMENSIONS

	INTERIOR (APPROX.)			DOOR OPENING (APPROX.) W/ DOOR INSTALLED	
	W	H	D	W	H
L1/R1	28	58	22/25	24.5	46.5
L2/R2	44	32	25	44	20.5
L3/R3	33	58	22/25	30	46.5
B1	42	59	40	42	36

INTERIOR CUBIC FEET: W X H X D / 1728

IMPORTANT NOTES

INIT. REV.	DESCRIPTION	DATE

DRAWN BY:	PC	CUSTOMER:	DEV STOCK
APPROVED BY:		DESCRIPTION:	DEV STOCK 2303 MINI PUMPER
PAGE:		SPEC. #:	
SCALE:		DATE: 10/20/2022	DWG. #: 2303



DEPENDABLE EMERGENCY VEHICLES

THIS DRAWING IS A CLOSE APPROXIMATION OF YOUR FIRE APPARATUS IN ALL CASES WHERE THE DRAWING AND THE WRITTEN SPECIFICATION DIFFER, THE SPECIFICATION SHALL PREVAIL. PLEASE WORK WITH YOUR DEALER TO ASSURE THAT THE WRITTEN SPECIFICATION REPRESENTS WHAT YOU WANT IN YOUR FINISHED PRODUCT

APPROVED BY CUSTOMER: _____ DATE: _____

SALES DRAWING MAY NOT REPRESENT CUSTOMER SPECIFICATION/ RFP AND/ OR TENDER IN IT'S ENTIRETY
ALL DIMENSIONS ARE IN INCHES

ALL DIMENSIONS ARE SUBJECT TO CHANGE DUE TO MANUFACTURING PROCESSES

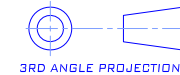
UNLESS OTHERWISE NOTED:
TOLERANCES ARE:  3RD ANGLE PROJECTION
THIS DRAWING IS THE CONFIDENTIAL PROPERTY OF DEPENDABLE EMERGENCY VEHICLES